



What's Next...

Enterprise Connections The Actualization of Affiliate Sales

Sal Dickinson, CEO
FloridaVacationAuction.com

What Is an Enterprise Connection?

- An Enterprise Connection Will Allow You to Connect Inventory, Rates, Booking Rules and Descriptive Content in your “Enterprise Platform” (Ticketing System) to WhomeverYouChoose.com to Facilitate Sales Transactions in Real Time

Why Should You Care?

The Travel Industry is Built on Connections & Interfaces

- PMS
- CRS
- Channel Manager
- CRM
- Revenue Management
- GDS
- ADS (Alternative Distribution Systems)
- Alternative Booking Solutions (Spa, Golf, Transport, Attractions, etc.)
- F&B and Retail POS

Hotel Distribution Environment

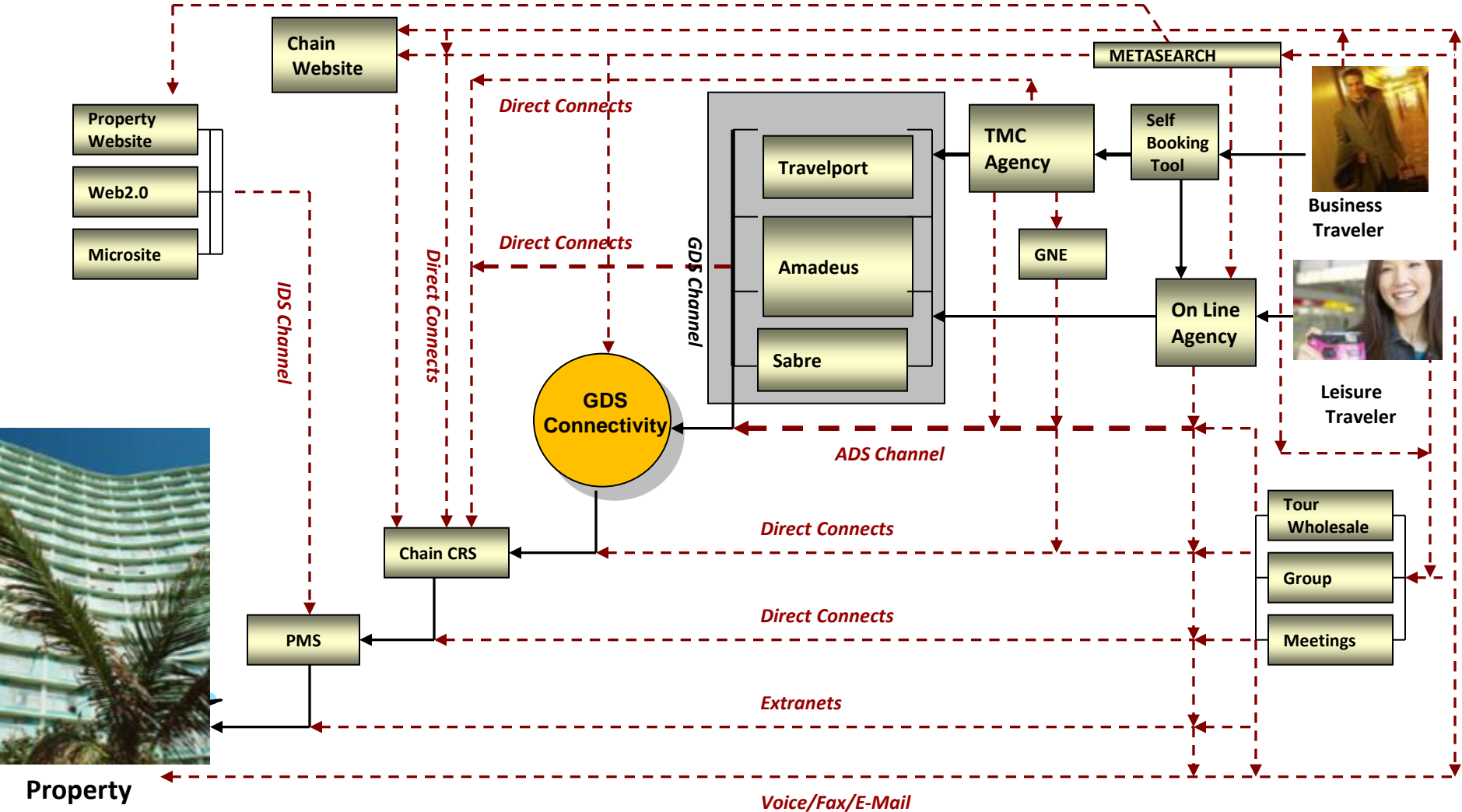

Channel Management connectivity schema

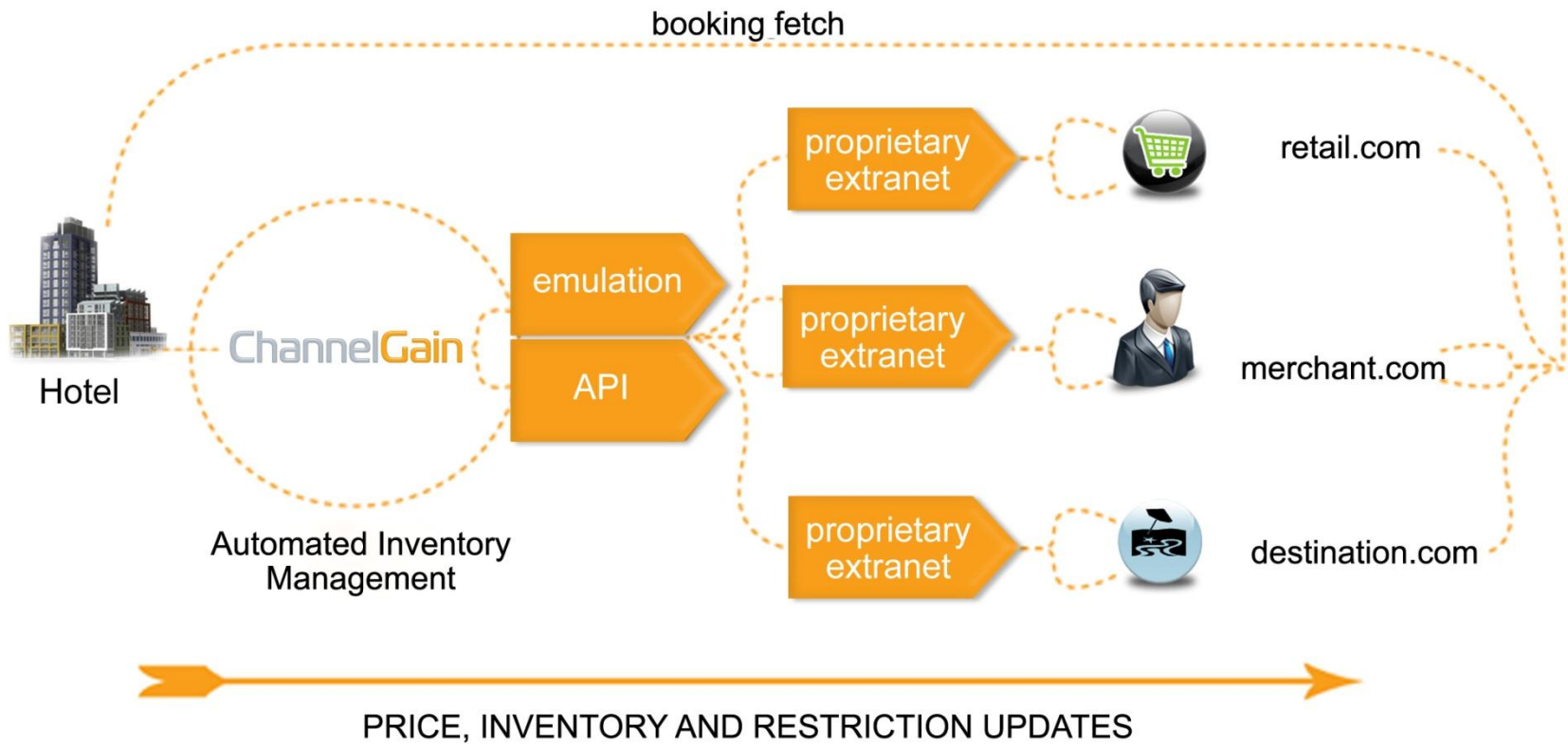

What Does This Mean To My Attraction?

- Simplified Packaging With Accommodations
 - Eliminates Physical Inventory & Reconciliation Headaches
- Transactions Occur Direct Within Your Ticketing Platform – The Customer Is YOURS
- The Cost of Transaction(s) at Fixed Schedule via Enterprise Connection Companies
- Little to No Investment Required for Interface*

What Does This Mean To My Attraction?

- Distribution Channels Will Become a Standard
- You Determine Connection Relationships or Channels that your Attraction Can Be Sold On – Hotel Websites, DMOs, Travel Agents, Online Travel Marketers (Florida Vacation Auction) – Even Other Attractions
- Your Channels Are Your Proxy Affiliates – Their Online Audience(s) Through Purchase Become YOUR CUSTOMERS!!!

When & How???

- Now. Early Technology Adoption Lifecycle in Hospitality (Approaching 10%)
- You **must** evolve to have an Enterprise Platform (Ticketing System; PMS for Hoteliers)
- Your Ticketing System Provider Must Have Open Code Compliance (Hotels Have HTNG – Hotel Technology Next Generation Trade Association <http://www.htng.org/>)

Do You???

Do You...

- Have An Electronic Ticketing System?
- Sell On Your Own Website?
- Want to Enable Others to Sell on Your Behalf in Real Time?
- Have a Ticketing Platform Vendor Who Is In The Business of Assuring Your Success?
- Want to Remain in Business in the Future?

THANK YOU

Sal Dickinson, CHME

CEO, Florida Vacation Auction

Questions?